

Evaluation Kit for PA04 and PA05 Power Amplifiers

APPLICABLE PARTS (SOLD SEPARATELY)

- PA04
- PA05

INTRODUCTION

This user-configurable kit provides a platform to evaluate the high-current linear power operational amplifiers, PA04 and PA05. The kit features interchangeable inverting/non-inverting capabilities, input and output transient protection, a kelvin-sense current limit with foldback considerations, isolated shut-down / sleep mode control, breadboarding area for building on-board boost-supplies, and a current-source option. All necessary components and hardware are provided. External high-current connections to the evaluation kit can be made through the terminal strip at the edge of the board. The input BNC connector has a line termination of 50 Ω.

Figure 1: Equivalent Schematic

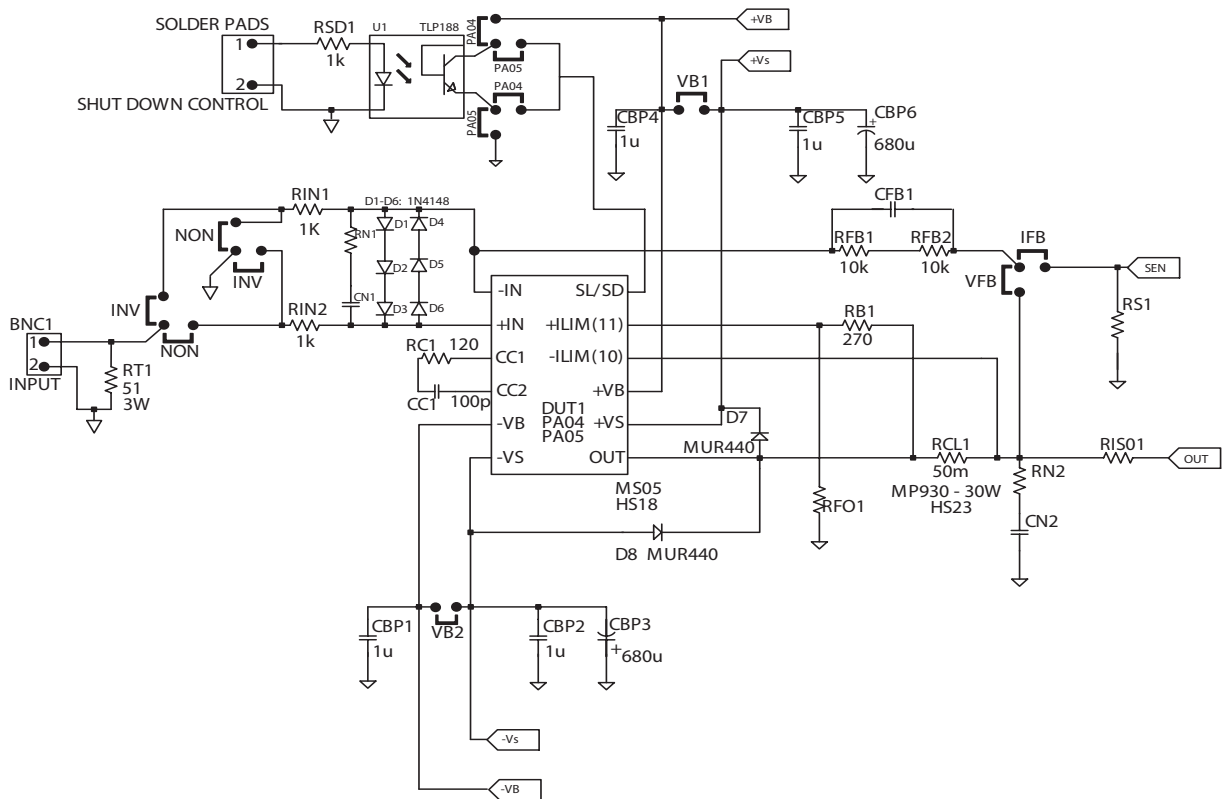
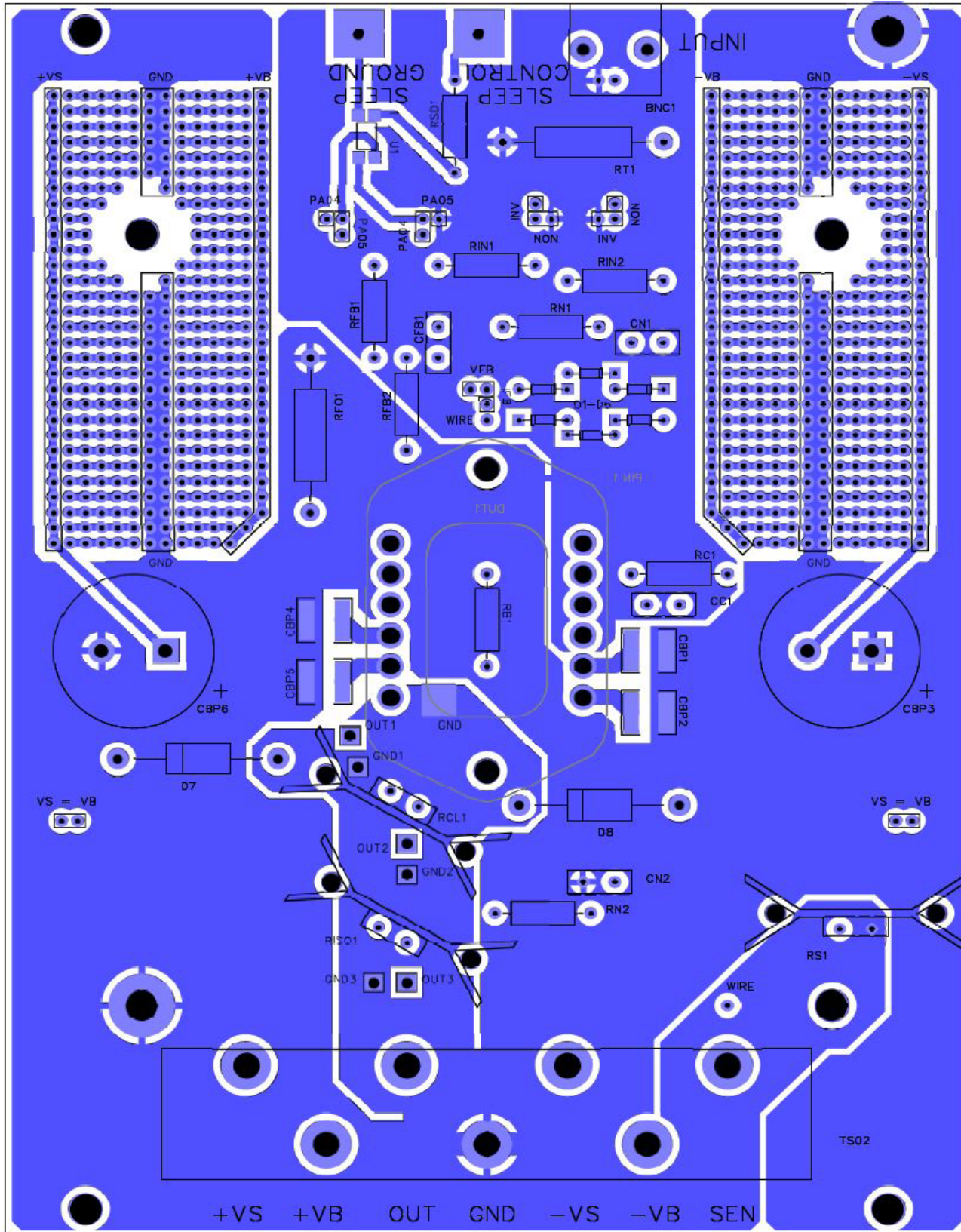

Figure 2: PCB Layout



PARTS LIST

HARDWARE

Designator	Manufacturer PN	Description	Qty
EVAL88		PCB	1
MS05		Mating socket	1
HS18		Heatsink	1
HS23		Heatsink	3
TW05		Thermal Washers (Pack of 10)	1
TS02	389690007	Terminal Strip	1
BNC1	146510CJ	BNC Connector	1
	90730A007	Nut, Hex, #6 X 1/4"	2
	91735A151	Screw, Panhead, #6 X 0.75"	2
	91841A009	Nut, Hex, #8	4
	8426	Spacer, Hex With Stud, #8 X 0.375"	4
	91735A190	Screw, Panhead, #8 X 0.25"	4
	2221	Standoff, Hex, #8 X 2.00"	4
	91735A192	Screw Panhead, #8 X 0.375"	4
	PRPC002SAAN-RC	2-pin Header	10
	SPC025VJN-RL	Slip-on Jumper	10
	TFT20014 NA005-6"	Tubing, Teflon, #18AWG, 6 Inches	1

ICS

Designator	Manufacturer PN	Description	Qty
U1	TLP188	Optoisolator	1

RESISTORS

Designator	Manufacturer PN	Description	Qty
RT1	PR03000205109JAC00	51 Ω , 3W, 5%	1
RIN1, RIN2, RSD1	PR01000101001JR500	1 k Ω , 1W, 5%	3
RB1	PR01000102700JR500	270 Ω , 1W, 5%	1
RC1	PR01000101200JR500	120 Ω , 1W, 5%	1
RFB1, RFB2	PR01000101002JR500	10 k Ω , 1W, 5%	2
RCL1	MP930-0.050-1%	50 m Ω , 30W, 1%	1

CAPACITORS

Designator	Manufacturer Pin	Description	Qty
CC1	CD15FD101FO3F	Ceramic, 100 pF, 500V	1
CBP1, 2, 4, 5	1825B105K201N	Ceramic Chip, 1 μ F, 200V	4
CBP3, 6	SLP681M200C7P3	Electrolytic, 680 μ F, 250V	2

DIODES

Designator	Manufacturer Pin	Description	Qty
D1-D6	1N4148-T	Switching Diode	6
D7, D8	MUR440G	Rectifier, Ultra-Fast	2

BEFORE YOU GET STARTED

- All Apex Microtechnology amplifiers should be handled using proper ESD precautions.
- Always use the heatsink and thermal washers included in this kit.
- Always use adequate power supply bypassing.
- Do not change the connections while the circuit is powered.
- Initially set all power supplies to the minimum operations levels allowed in the device data sheet.
- Check for oscillations.
- Please refer to Application Note, AN01 for general operating conditions.

ASSEMBLY

During the assembly, refer to the circuit schematics, assembly drawings, and the data sheet of the part being used on the evaluation kit.

1. Note that each side of the circuit board is identified as either the component side or the DUT side. The component side has the designators printed on that side. All the components, except the mating socket and surface mount components, are installed on the component side of the board and soldered on the DUT side.
2. First install the surface mount capacitors CBP1, 2, 4, and 5, as well as the optoisolator U1, on the component side. RB1 should also be installed at this point.
3. A power DIP socket (MS05) is supplied with this kit. The MS05 socket incorporates two cavities to retain the #6 x 1/4" nuts (90730A007). Insert one #6 nut into each cavity. Make sure the nuts are fully seated into the cavities. Insert the socket from the DUT side of the board with the #6 nuts in the cavities.
4. Attach the heatsink to the board from the DUT side, using #8 x 0.25" screws and spacers. Refer to the assembly drawings for the correct way to attach the heatsink. This is done to keep the socket tightly mounted to the board and eliminate stress so that the socket pins do not move while being soldered from the component side. Once the socket pins are soldered, the socket is attached to the board; remove the heatsink and all the screws.
5. Now install and solder the smaller components to the component side, such as RT1, RSD1, RIN1, RIN2, RFB1, RFB2, D1-D8, RC1, and CC1. This is done because it becomes more difficult to install a smaller part on the board once all the larger components are mounted. Ensure that the orientation of the diodes match the circuit schematic.
6. 10 two-pin header sets are included in the kit. 2 of these should be installed at the designators "VS = VB". Next, there are five positions on the board with L-shaped configurable jumper positions, designated "PA04/PA05" (x2), "NON/INV" (x2), and "VFB/IFB" (x1). These each require one 2-pin header, as well as a

single header pin, cut from a pair, to complete the “L.” The provided jumper sleeves may be placed at each pin header location (only 7 of the 10 provided may be required). Configuration instructions are provided below.

7. Mount electrolytic capacitors CBP3 and CBP6. Ensure that the orientation of the electrolytic capacitors match the circuit schematic.
 8. Attach the 50 mΩ resistor to one of the HS23 heatsinks provided, using thermal paste (not included) and a #4 screw and nut (not included). Mount this into the designator “RCL1” and solder the leads of the resistor from the DUT side. This will provide a current limit of roughly 14 A. If a different current limit is desired, other resistor values and/or heatsinks may be required. If no current limit is desired, this designator MUST be shorted. If RCL1 is left unpopulated, the amplifier will operate open-loop.
 9. If an isolation resistor or sense resistor is desired, repeat step 8 with an appropriate resistor value and designator. If an isolation resistor is not desired, RISO1 MUST be shorted. If RISO1 is left unpopulated, the output will not be connected to the terminal strip. RS1 may be left unpopulated.
 10. Mount the BNC connector provided with the kit and solder it to the board. Also mount the terminal strip (TS02) provided in the kit. Refer to the assembly drawings before mounting the terminal strip. Make sure the terminal strip sits flat against the circuit board.
 11. #8 x 2” hex stand offs are also provided with the kit. Install to the corners of the board with the # 8 x 0.375” screws. Refer to the assembly drawings while installing the standoffs.
 12. Attach the heatsink as in step 4. Cut the Teflon tubing into 12 pieces, each of length 0.21 inches or 5.33 mm (1/5 of an inch) approximately. These pieces go onto the pins of the Power Amplifier before inserting it into the socket. This is done to insulate the pins from the heatsink and make sure that the PA is tightly fixed into the socket. An Exacto knife works well for this.
- Note:** The Teflon pieces should not be longer than the suggested length. If the pieces are longer, they may interfere in the seating of the part to the heatsink and create a gap between the heatsink and the part body.
13. Ten thermal washers (TW05) are provided with the kit. The thermal washer is used between the part and the heatsink. A new washer must be used for each mounting. Mount the Power Amplifier to the socket using the thermal washer provided with the kit. Secure with the #6 screws. Note: the notch in the case of the amplifier should point to the input BNC for correct orientation.

Figure 3: Top Assembly

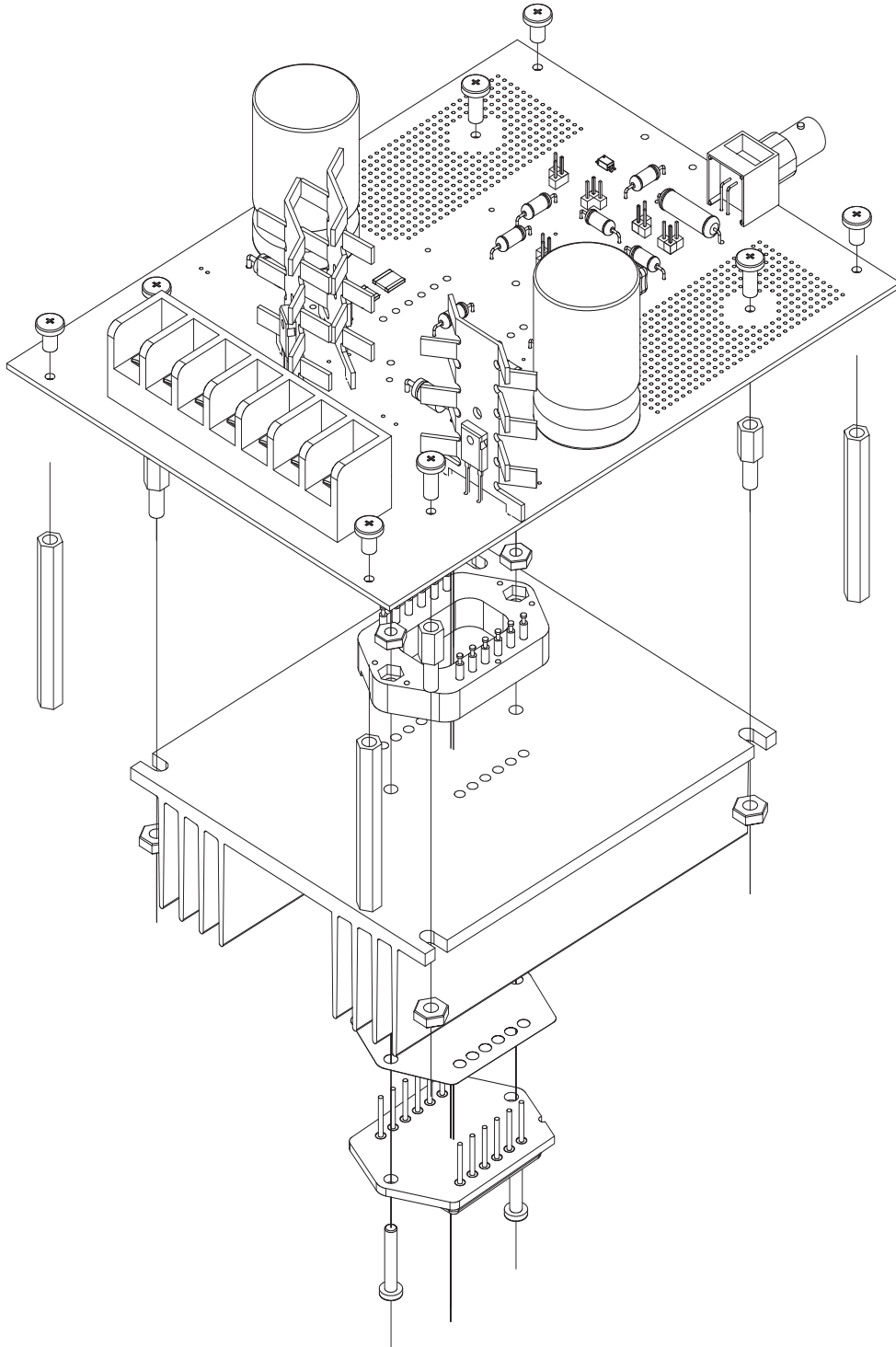
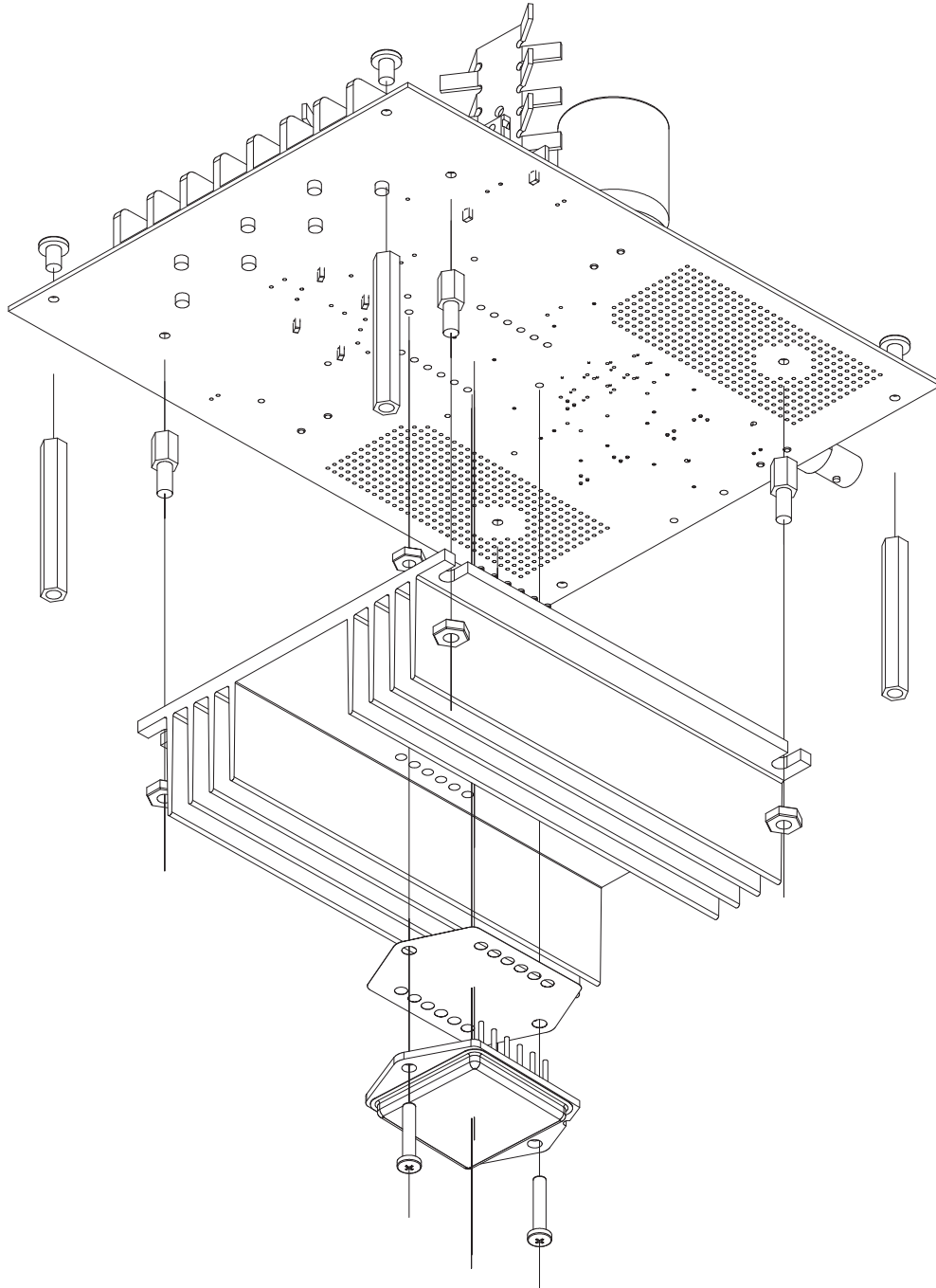

Figure 4: Bottom Assembly



INVERTING/NON-INVERTING

The evaluation kit can easily be changed between inverting and non-inverting modes of operation. For inverting, apply two jumper sleeves next to the designators “INV.” The gain, using the provided resistors, will be -20 V/V. For non-inverting, switch the two jumper sleeves to align with the designators “NON.” The gain, using the provided resistors, will be +21 V/V.

SLEEP/SHUTDOWN FEATURES

Both PA04 and PA05 have functions to turn off the output and reduce power consumption when a signal is applied to pin 12. However, due to the unique topologies of each amplifier, these must be configured differently. For PA04, apply two jumper sleeves next to the designators “PA04.” For PA05, switch the two jumper sleeves to align with the designators “PA05.”

Caution: PA04 can suffer catastrophic failure if Sleep is enabled with the wrong configuration. Double check the jumper sleeve positions before applying power to the circuit and before initiating Sleep. If the Sleep / Shutdown features will not be evaluated, the jumpers may be removed.

To enable Sleep / Shutdown, apply 5 to 10 V across the “Sleep Control” and “Sleep Ground” pads. These pads are compatible with alligator clips, banana jacks, bare wire soldered down, etc. It is recommended that the input to the BNC connector be set to 0V before sleep / shutdown are initiated to avoid transient voltage conditions.

VOLTAGE SOURCE/ CURRENT SOURCE

For voltage source applications, a jumper sleeve must be applied next to the designator “VFB.” This will connect the feedback resistor to the output node.

For current source applications, an insulated wire (not included) must be routed between the two holes designated “WIRE”. Then, a jumper sleeve must be applied next to the designator “IFB.” This will connect the feedback resistor to the sense node. Make sure an appropriate current sense resistor (RS1) is installed, and connect the load between “OUT” and “SEN” on the terminal strip. It is recommended to first test with a resistive (>10 kΩ) load. Feedback resistors and input signal may need to be adjusted for proper current source operation.

FOLDBACK CURRENT LIMIT

The Current Limit scheme of PA04 and PA05 is capable of decreasing the current limit as a function of output voltage, to better match the safe operating area of the part. To enable this feature, solder a “foldback resistor” to RFO1. Typical values range from 10kΩ to 50kΩ. The current limit can then be calculated as:

$$I_{CL} = \frac{0.7V + |V_{OUT}| \times \left(\frac{270\Omega}{R_{FO} + 270\Omega} \right)}{R_{CL}}$$

Where R_{FO} and R_{CL} are in [Ω], and I_{CL} is in [A]. See Apex Application Note AN09 “Current Limiting” for more details. Foldback current limiting is not recommended for highly reactive loads.

If foldback current limiting is not desired, leave RFO1 unpopulated.

BOOST SUPPLIES

Although the breadboarding area on either side of the board may be used for any application, it is designed especially for use in building boost-supply circuitry. PA04 and PA05 may operate with slightly higher supplies for the input stages in order to drive the output stage further into saturation; this will improve volt-

age swing and efficiency. These boost supplies ($\pm V_B$) need only be 5V to 10V greater than $\pm V_S$, and they need only provide the input stage quiescent current of the part (up to 56 mA).

For normal operation, both “VS = VB” designators may be sleeved. For boost operation, un-sleeve these pins, then the boost supplies may be applied externally through the terminal strip or built on the board using the breadboarding area.

HIGH-FIDELITY LOAD MOUNTING POINTS

High-power analog can be extremely sensitive to layout and trace length. For applications where high signal fidelity is essential, three mounting points have been provided for connection to a load. These provide much shorter trace lengths and lower impedance in the high-current paths. The mounting points are recommended for use with a “twisted pair” or coaxial wire connection to the load.

An exposed ground pad has also been supplied directly next to the output pin of the amplifier on the component side. For better trace-decoupling, a connection to power ground may be soldered to this pad.

For applications where high signal fidelity is not important, all supply and load connections may be made through the terminal strip.

STABILITY CONSIDERATIONS

This evaluation kit provides considerations for phase compensation, noise gain compensation, feedback zero compensation, an R-C output snubber network, and an isolation resistor to help stabilize circuits. Please see Apex Application Note AN01 General Operating Considerations for more information on Op-Amp stability.

OTHER HEATSINK OPTIONS

With the heatsink provided, HS18, properly installed, the amplifier is capable of dissipating up to 59 W before reaching the maximum operating temperature of 85°C. For higher power applications, forced air or larger heatsinks may be necessary. Using Apex heatsink HS11 (not included), the amplifier may safely dissipate up to 87 W in free air, or up to 175 W with 1 Gallon per Minute per channel of 25°C water cooling. The evaluation board includes mounting holes for HS11.

TEST ASSEMBLY

EQUIPMENT NEEDED

1. Power Supply
2. Function Generator
3. Oscilloscope with Probe(s)
4. Proper Heatsinking System

TEST SETUP

Connect the power supply to the terminal strip. Connect the BNC cable from the function generator to the BNC connector marked INPUT, mounted on the board. Connect the load to the terminals on the terminal strip. Refer to the amplifier datasheet for typical values of input voltage, frequency and supply voltage. Attach oscilloscope probe(s) at desired nodes. Begin the test with minimum values of input and supply voltage.

Note: After everything is connected, switch on the power to the board, and check the socket at each pin (without the DUT) for correct voltage / signal at each respective pin. Once this is done, plug in the DUT and check for the correct signal.

TEST RESULTS

Figure 5 shows input (yellow waveform) and output (blue waveform) for a PA04 power amplifier connected to a resistive load. The part was tested for an input voltage of 500mV p-p, at 10 kHz frequency. The supply voltage is set at ±20 Volts.

Figure 5: Test Waveforms

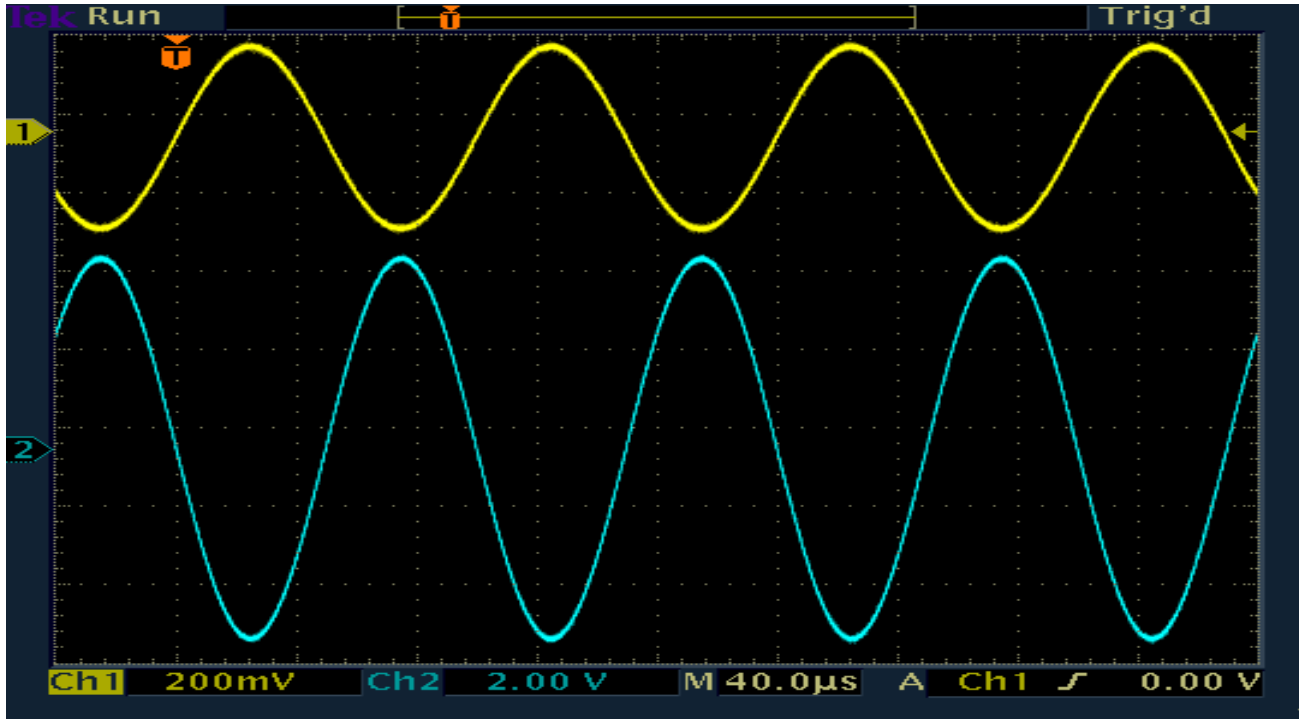

NEED TECHNICAL HELP? CONTACT APEX SUPPORT!

For all Apex Microtechnology product questions and inquiries, call toll free 800-546-2739 in North America. For inquiries via email, please contact apex.support@apexanalog.com. International customers can also request support by contacting their local Apex Microtechnology Sales Representative. To find the one nearest to you, go to www.apexanalog.com

IMPORTANT NOTICE

Apex Microtechnology, Inc. has made every effort to insure the accuracy of the content contained in this document. However, the information is subject to change without notice and is provided "AS IS" without warranty of any kind (expressed or implied). Apex Microtechnology reserves the right to make changes without further notice to any specifications or products mentioned herein to improve reliability. This document is the property of Apex Microtechnology and by furnishing this information, Apex Microtechnology grants no license, expressed or implied under any patents, mask work rights, copyrights, trademarks, trade secrets or other intellectual property rights. Apex Microtechnology owns the copyrights associated with the information contained herein and gives consent for copies to be made of the information only for use within your organization with respect to Apex Microtechnology integrated circuits or other products of Apex Microtechnology. This consent does not extend to other copying such as copying for general distribution, advertising or promotional purposes, or for creating any work for resale.

APEX MICROTECHNOLOGY PRODUCTS ARE NOT DESIGNED, AUTHORIZED OR WARRANTED TO BE SUITABLE FOR USE IN PRODUCTS USED FOR LIFE SUPPORT, AUTOMOTIVE SAFETY, SECURITY DEVICES, OR OTHER CRITICAL APPLICATIONS. PRODUCTS IN SUCH APPLICATIONS ARE UNDERSTOOD TO BE FULLY AT THE CUSTOMER OR THE CUSTOMER'S RISK.

Apex Microtechnology, Apex and Apex Precision Power are trademarks of Apex Microtechnology, Inc. All other corporate names noted herein may be trademarks of their respective holders.